

Problems with a (d) will have a decimal answer. Round these answers to the nearest hundredth. All other answers must be left in simplified radical form.

1)

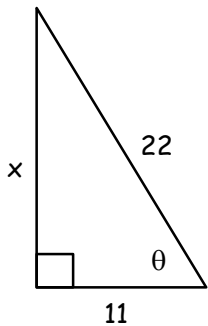

$x = \underline{\hspace{2cm}}$
(d) $\theta = \underline{\hspace{2cm}}$

2)

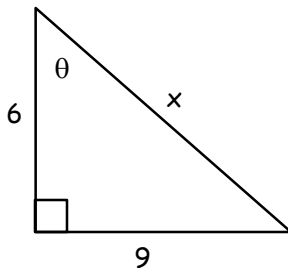

$x = \underline{\hspace{2cm}}$
(d) $\theta = \underline{\hspace{2cm}}$

3)

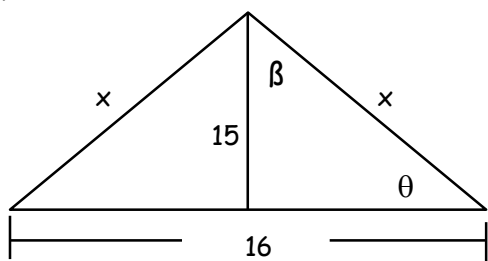

$x = \underline{\hspace{2cm}}$
(d) $\theta = \underline{\hspace{2cm}}$
(d) $\beta = \underline{\hspace{2cm}}$

4)

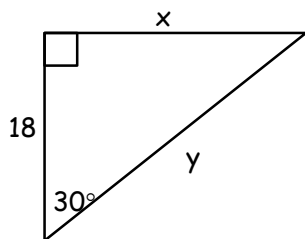

$x = \underline{\hspace{2cm}}$
 $y = \underline{\hspace{2cm}}$

5)

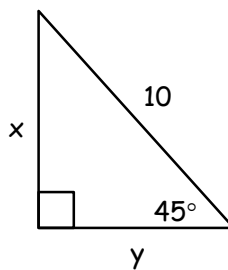

$x = \underline{\hspace{2cm}}$
 $y = \underline{\hspace{2cm}}$

6)

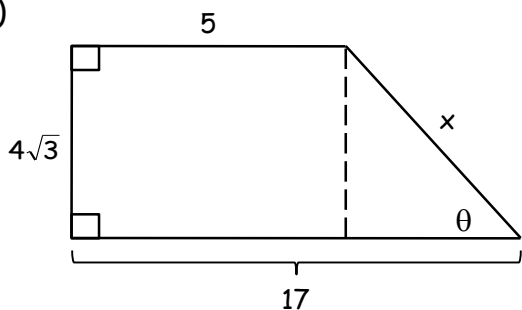

$x = \underline{\hspace{2cm}}$
(d) $\theta = \underline{\hspace{2cm}}$

Problems with a (d) will have a decimal answer. Round these answers to the nearest hundredth. All other answers must be left in simplified radical form.

7)

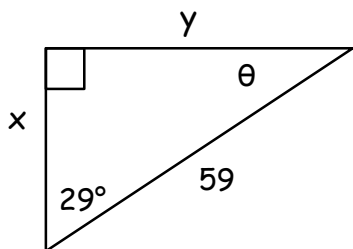

(d) $x =$ _____

(d) $y =$ _____

$\theta =$ _____

8)

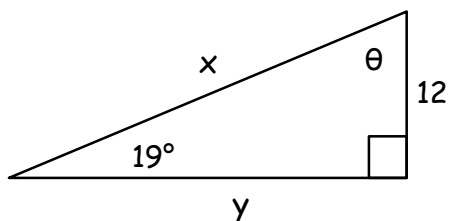

(d) $x =$ _____

(d) $y =$ _____

$\theta =$ _____

9)

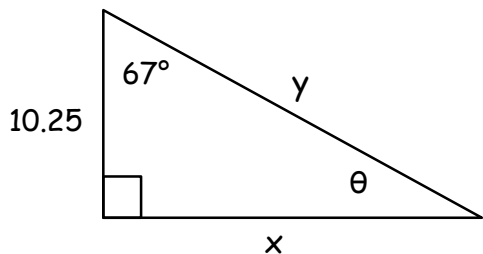

(d) $x =$ _____

(d) $y =$ _____

$\theta =$ _____

Directions: Express each value as a fraction. Leave all answers in simplified radical form.

10)

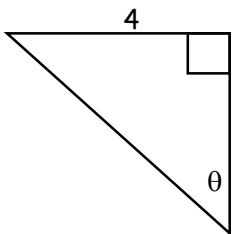

$\sin \theta =$

$\cos \theta =$

$\tan \theta =$

11)

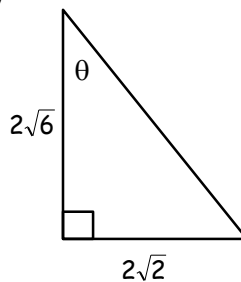

$\sin \theta =$

$\cos \theta =$

$\tan \theta =$

Geometry/Trig
Unit 7 Review Packet

Directions: Complete each word problem. Leave answers in simplified radical form.

12) Simplify completely.

a) $\sqrt{75} \cdot \sqrt{2}$ b) $(4\sqrt{6})^2$ c) $4\sqrt{18} \cdot 2\sqrt{5}$

13) Simplify completely.

a) $\frac{6\sqrt{6}}{\sqrt{12}}$

b) $\sqrt{\frac{5}{8}}$

14) Can a triangle be constructed with side lengths 4, 5, and 8? If so, determine whether the triangle could be a right, acute or obtuse triangle.

15) Can a triangle be constructed with side lengths 5, 7, and 8? If so, determine whether the triangle could be a right, acute or obtuse triangle.

16) An isosceles triangle has side lengths 6, 6 and 10. Find the length of the altitude drawn to the base.

17) The diagonal of a square has a length of 12in. Find the perimeter of the square.

18) An equilateral triangle has a perimeter of 42 inches. Find the length of the altitude.

19) A rhombus has diagonals of lengths 10m and 24m. Find the perimeter of the rhombus.

Geometry/Trig
Unit 7 Review Packet

Directions: Complete each word problem. Round answers to the nearest hundredth.

20) You and a friend wave to each other from the top of two buildings. You are looking up at your friend at an angle of 18° angle of elevation. You are standing on a 763 foot building. The height of the building that your friend is on is 795 feet. What is the approximate distance between the two buildings?

21) A tree casts a shadow 81 feet long. The angle of elevation from the end of the shadow to the sun is 42° . What is the height of the tree?

22) A kite is 38 feet above the ground. The child is holding the end of the kite string 4 feet above the ground. The kite string makes a rising angle (angle of elevation) of 42° from the line of sight. Assuming that the string is pulled tight, how much string is out?

23) You are in a lighthouse communicating with a ship offshore. You want to determine how far the ship is from the cliff that the lighthouse is on, given that the top of the lighthouse is 200 feet above sea level and the angle of depression is 20° . How far away is the ship? If a person on the ship looks up at the top of the lighthouse, what is the angle of elevation?